

4

3

2

1

MATERIAL & FINISH

- 1 BODY: BRASS, GOLD PLATED
- 2 CENTER CONTACT: BRASS, GOLD PLATED
- 3 FASTENING NUT: BRASS, GOLD PLATED
- 4 INSULATOR: PTFE
- 5 LOCK WASHER: PHOSPHOR BRONZE, GOLD PLATED

ENVIRONMENTAL DATA:

- 1 TEMPERATURE RANGE: -55°C~+125°C
- 2 2011/65/EU (RoHS): COMPLIANT

ELECTRICAL DATA:

- 1 IMPEDANCE: 50 OHMS
- 2 FREQUENCY RANGE: DC~6 GHZ
- 3 VSWR: 1.50 MAX.

REVISIONS			
REV.	DESCRIPTION	DATE	APPROVED
C	PART NUMER CHANGED	08/10/10	J. QU
D	DRAWING FORMAT CHANGED	07/17/17	J. QU

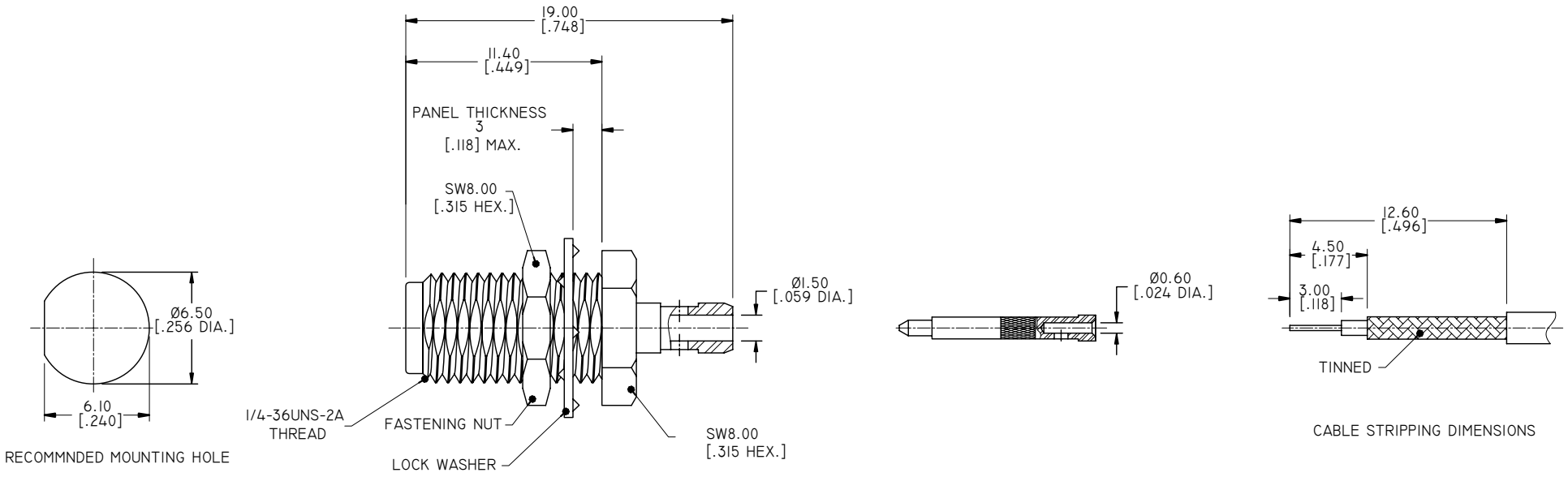

DRAWN	P. CHEN	DATE	07/17/17
CHECKED	L. YANG	DATE	07/17/17
APPROVED	J. QU	DATE	07/17/17
UNLESS OTHERWISE SPECIFIED DIMENSIONS ARE IN MILLIMETERS. DIMENSIONS IN [] ARE IN INCHES FOR CUSTOMER REFERENCE ONLY UNLESS OTHERWISE SPECIFIED TOLERANCE ARE:		THESE DRAWINGS AND SPECIFICATIONS ARE THE PROPERTY OF ANOISON ELECTRONICS LTD AND SHOULD NOT BE USED WITHOUT WRITTEN PERMISSION COPYRIGHT © 2017 ANOISON ELECTRONICS LTD	
.XX	±0.13 [.005"]		
.X	±0.20 [.008"]		
X	±0.50 [.019"]		
.X°	±1°		
X°	±2°		



TITLE				
RP SMA STRAIGHT FEMALE SOLDER FOR RG178 CABLE				
VIEW		PART NO.		
		ANO 2114-1011		
SIZE	SCALE	SHEET	REV.	
A3	4:1	1/1	D	

4

3

2

1