

1.0 MATERIAL & FINISH

- 1.1 BODY: STAINLESS STEEL, PASSIVATED
- 1.2 CENTER CONTACT: BERYLLIUM COPPER ALLOY, GOLD PLATED
- 1.3 WASHER: PHOSPHOR BRONZE, NICKEL PLATED
- 1.4 FASTENING NUT: BRASS, NICKEL PLATED
- 1.5 INSULATOR: PTFE

2.0 ENVIRONMENTAL DATA:

- 2.1 TEMPERATURE RANGE: -55°C~+125°C
- 2.2 2011/65/EU (RoHS): COMPLIANT

3.0 ELECTRICAL DATA:

- 3.1 IMPEDANCE: 50 Ω
- 3.2 FREQUENCY RANGE: DC~6 GHz

REVISIONS			
REV.	DESCRIPTION	DATE	APPROVED
A	INITIAL RELEASE	08/05/11	J. QU
B	DRAWING FORMAT CHANGED	08/01/17	J. QU

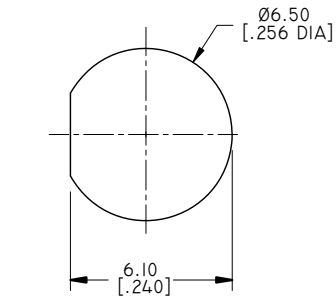

RECOMMENDED MOUNTING HOLE

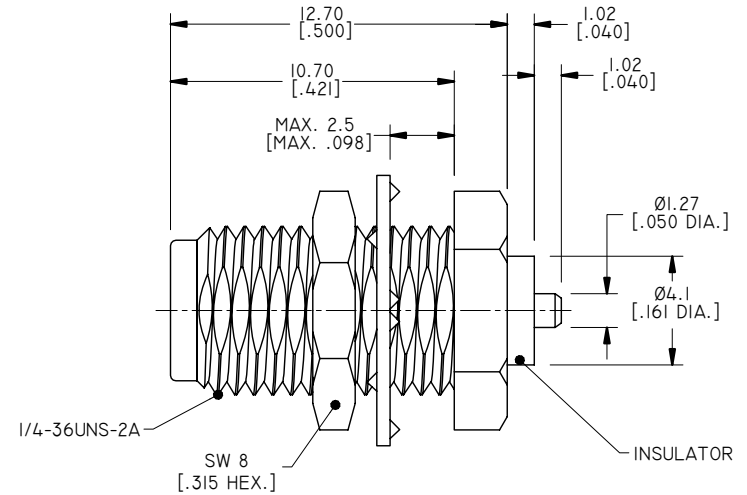
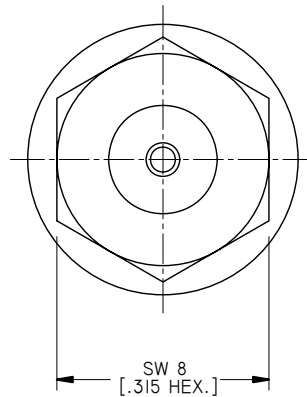

DRAWN	P. CHEN	DATE	08/01/17
CHECKED	L. YANG	DATE	08/01/17
APPROVED	J. QU	DATE	08/01/17
UNLESS OTHERWISE SPECIFIED DIMENSIONS ARE IN MILLIMETERS. DIMENSIONS IN [] ARE IN INCHES FOR CUSTOMER REFERENCE ONLY UNLESS OTHERWISE SPECIFIED TOLERANCE ARE:		THESE DRAWINGS AND SPECIFICATIONS ARE THE PROPERTY OF ANOISON ELECTRONICS LTD AND SHOULD NOT BE USED WITHOUT WRITTEN PERMISSION COPYRIGHT © 2017 ANOISON ELECTRONICS LTD	
.XX	±0.13 [0.005"]		
.X	±0.20 [0.008"]		
X	±0.50 [0.019"]		
.X°	±1°		
X°	±2°		



TITLE			
SMA STRAIGHT BULKHEAD FEMALE, END SOLDER, EXTENDED INSULATOR			
VIEW		PART NO.	
		ANO 2112-5154	
SIZE	SCALE	SHEET	REV.
A3	5:1	1/1	B