

4

3

2

1

MATERIAL & FINISH

- 1 BODY: SEE TABLE
- 2 CENTER CONTACT: BERYLLIUM COPPER ALLOY, GOLD PLATED
- 3 FASTENING NUT: SEE TABLE
- 4 INSULATOR: PTFE
- 5 LOCK WASHER: PHOSPHOR BRONZE, ALBALOY PLATED

ENVIRONMENTAL DATA:

- 1 TEMPERATURE RANGE: -55°C~+125°C
- 2 2011/65/EU (RoHS): COMPLIANT

ELECTRICAL DATA:

- 1 IMPEDANCE: 50 OHMS
- 2 FREQUENCY RANGE: DC~6 GHZ
- 3 VSWR: 1.30 MAX.

REVISIONS			
REV.	DESCRIPTION	DATE	APPROVED
C	STRUCTURE CHANGED	12/04/13	J. QU
D	DRAWING FORMAT CHANGED	08/03/17	J. QU
E	ADDED PLATED AND P/N	09/26/19	J. QU

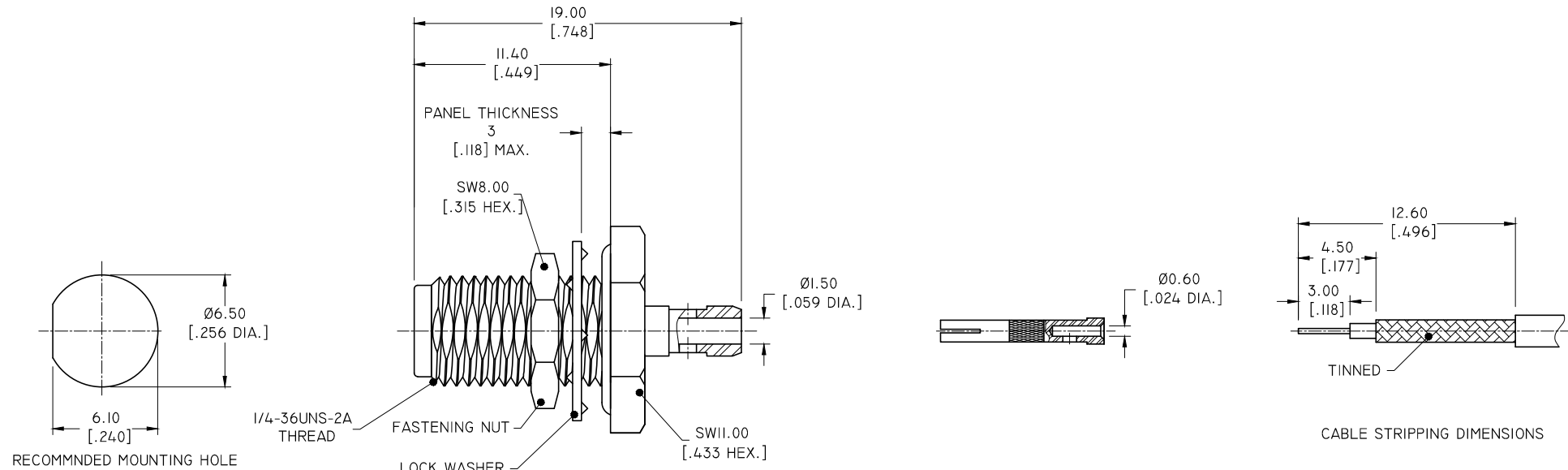

TABLE

PART NO.	PART	MATERIAL	FINISH
ANO 2112-1138	BODY	BRASS	ALBALOY
	FASTENING NUT	BRASS	GOLD
ANO 2112-1138-1	BODY	BRASS	GOLD
	FASTENING NUT	BRASS	GOLD
ANO 2112-1138-2	BODY	STAINLESS STEEL	GOLD
	FASTENING NUT	STAINLESS STEEL	PASSIVATED

DRAWN	P. CHEN	DATE	09/26/19
CHECKED	L. YANG	DATE	09/26/19
APPROVED	J. QU	DATE	09/26/19
UNLESS OTHERWISE SPECIFIED DIMENSIONS ARE IN MILLIMETERS. DIMENSIONS IN [ ] ARE IN INCHES FOR CUSTOMER REFERENCE ONLY UNLESS OTHERWISE SPECIFIED TOLERANCE ARE:		THESE DRAWINGS AND SPECIFICATIONS ARE THE PROPERTY OF ANOISON ELECTRONICS LTD AND SHOULD NOT BE USED WITHOUT WRITTEN PERMISSION COPYRIGHT © 2019 ANOISON ELECTRONICS LTD	
	.XX	±0.13	[.005"]
	.X	±0.20	[.008"]
	X	±0.50	[.019"]
	.X°	±1°	
	X°	±2°	



SMA STRAIGHT FEMALE WATERPROOF SOLDER FOR RG178 CABLE

VIEW	PART NO. ANO 2112-1138			
	SIZE	SCALE	SHEET	REV.
	A3	4:1	1/1	E

4

3

2

1