

4

3

2

1

**MATERIAL & FINISH:**

- 1 BODY : STAINLESS STEEL, PASSIVATED
- 2 CENTER CONTACT: BRASS, GOLD PLATED
- 3 INSULATOR: PTFE
- 4 COUPLING NUT: STAINLESS STEEL, PASSIVATED
- 5 SOLDER FERRULE: BRASS, GOLD PLATED

**ELECTRICAL DATA:**

- 1 IMPEDANCE: 50 OHMS
- 2 FREQUENCY RANGE: DC~26.5 GHz
- 3 VSWR: 1.30 MAX.

**ENVIRONMENTAL DATA:**

- 1 TEMPERATURE RANGE: -55°C~+165°C
- 2 2011/65/EU(RoHS) AND 2015/863/(RoHS): COMPLIANT
- 3 1999/45/EC(REACH): COMPLIANT

REVISIONS			
REV.	DESCRIPTION	DATE	APPROVED
A	INITIAL RELEASE	11/24/21	J. Q

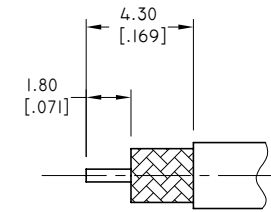
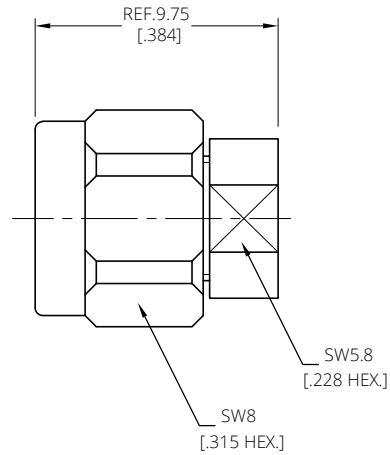



CABLE STRIPPING DIMENSIONS

DRAWN	W. Y	DATE	11/24/21
CHECKED	X. Y	DATE	11/24/21
APPROVED	J. Q	DATE	11/24/21
UNLESS OTHERWISE SPECIFIED DIMENSIONS ARE IN MILLIMETERS, DIMENSIONS IN [ ] ARE IN INCHES FOR CUSTOMER REFERENCE ONLY UNLESS OTHERWISE SPECIFIED TOLERANCE ARE:		THESE DRAWINGS AND SPECIFICATIONS ARE THE PROPERTY OF ANOISON ELECTRONICS LTD AND SHOULD NOT BE USED WITHOUT WRITTEN PERMISSION COPYRIGHT © 2023 ANOISON ELECTRONICS LTD	
	XX	±0.13 [005"]	
	X	±0.20 [008"]	
	x	±0.50 [019"]	
	x°	±1°	
	x°	±2°	



TITLE  
SMA STRAIGHT MALE SOLDER FOR MB103 CABLE

VIEW  

PART NO.  
ANO 2111-2611

SIZE A3	SCALE 5:1	SHEET 1/1	REV. A
------------	--------------	--------------	-----------

4

3

2

1