

REVISIONS			
REV.	DESCRIPTION	DATE	APPROVED
A	INITIAL RELEASE	11/12/15	J. QU
B	DRAWING FORMAT CHANGED	07/21/17	J. QU
C	SMA COUPLING NUT CHANGED	11/09/20	J. QU

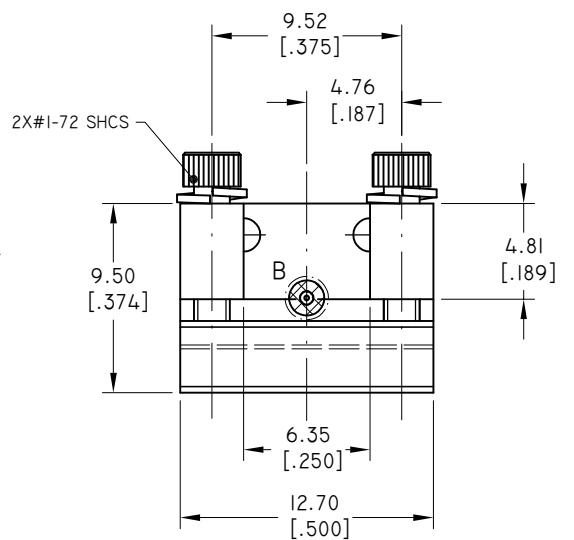
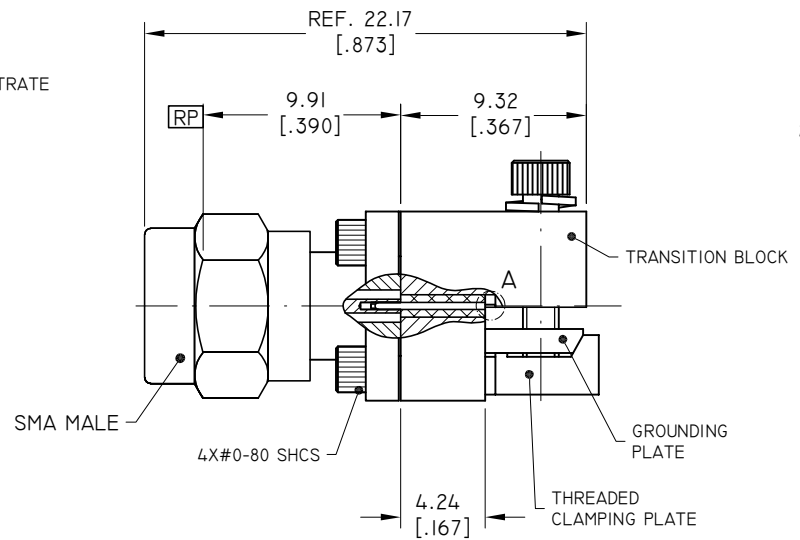
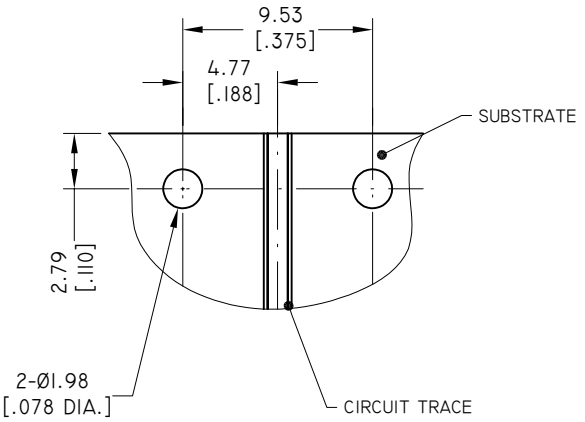

SMA CONNECTOR

1. BODY: STAINLESS STEEL, PASSIVATED
2. CENTER CONTACT: BERYLLIUM COPPER ALLOY, GOLD PLATED
3. INSULATOR: PTFE
4. CAPTURE BEAD: PEI
5. COUPLING NUT: STAINLESS STEEL, PASSIVATED

TRANSITION BLOCK

1. TRANSITION BLOCK: BRASS, NICKEL PLATED
2. GROUNDING PLATE: BRASS, NICKEL PLATED
3. THREADED CLAMPING PLATE: BRASS, NICKEL PLATED
4. LAUNCH PIN: BERYLLIUM COPPER ALLOY, GOLD PLATED
5. TRANSITION BLOCK DIELECTRIC: PTFE

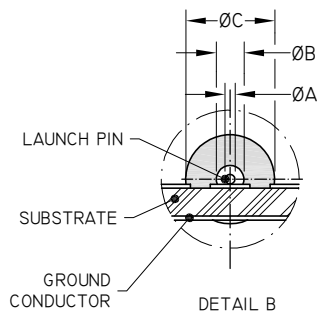
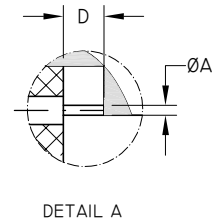

PART NO.	Ø A	Ø B	Ø C	D
ANO 211-A1-H	0.13 [.005]	0.23 [.009]	0.74 [.0290]	0.76 [.030]
ANO 211-A2-H	0.18 [.007]	0.31 [.012]	0.99 [.0390]	0.76 [.030]
ANO 211-A3-H	0.18 [.007]	0.38 [.015]	1.22 [.0480]	0.76 [.030]
ANO 211-A4-H	0.25 [.010]	0.51 [.020]	1.61 [.0635]	1.27 [.050]

DRAWN	W. YANG	DATE	11/09/20
CHECKED	X. B. YANG	DATE	11/09/20
APPROVED	J. QU	DATE	11/09/20
UNLESS OTHERWISE SPECIFIED DIMENSIONS ARE IN MILLIMETERS, DIMENSIONS IN [] ARE IN INCHES FOR CUSTOMER REFERENCE ONLY UNLESS OTHERWISE SPECIFIED TOLERANCE ARE:		THESE DRAWINGS AND SPECIFICATIONS ARE THE PROPERTY OF ANOISON ELECTRONICS LTD AND SHOULD NOT BE USED WITHOUT WRITTEN PERMISSION COPYRIGHT © 2020 ANOISON ELECTRONICS LTD	
.XX	±0.13 [.005"]		
.X	±0.20 [.008"]		
X°	±0.50 [.019"]		
X°	±1°		
X°	±2°		

ANOISON

TITLE: SMA MALE END LAUNCH CONNECTOR

VIEW:

PART NO.: ANO 211-AX-H

SIZE	SCALE	SHEET	REV.
A3	4:1	1/1	C