

MATERIAL & FINISH:

- 1 BODY: BRASS, ALBALOY PLATED
- 2 CENTER CONTACT: BERYLLIUM COPPER ALLOY, GOLD PLATED
- 3 INSULATOR: PTFE
- 4 FASTENING NUT: BRASS, ALBALOY PLATED
- 5 LOCK WASHER: PHOSPHOR BRONZE, ALBALOY PLATED
- 6 O-RING: SILICONE RUBBER

ENVIRONMENTAL DATA:

- 1 TEMPERATURE RANGE: -55°C~+85°C
- 2 2011/65/EU(RoHS) AND 2015/863/(RoHS): COMPLIANT
- 3 1999/45/EC(REACH): COMPLIANT

ELECTRICAL DATA:

- 1 IMPEDANCE: 50 Ω
- 2 FREQUENCY RANGE: DC~18 GHZ

REVISIONS

REV.	DESCRIPTION	DATE	APPROVED
A	INITIAL RELEASE	06/23/17	J. QU
B	1. ANO PART NO. ANO I411-2007 WAS ANO I412-2007 2. 2015/863/(RoHS): COMPLIANT ADDED 3. 1999/45/EC(REACH): COMPLIANT ADDED	09/21/18	J. QU

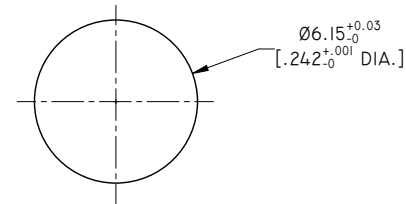
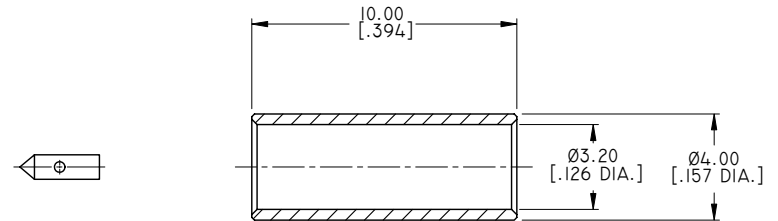
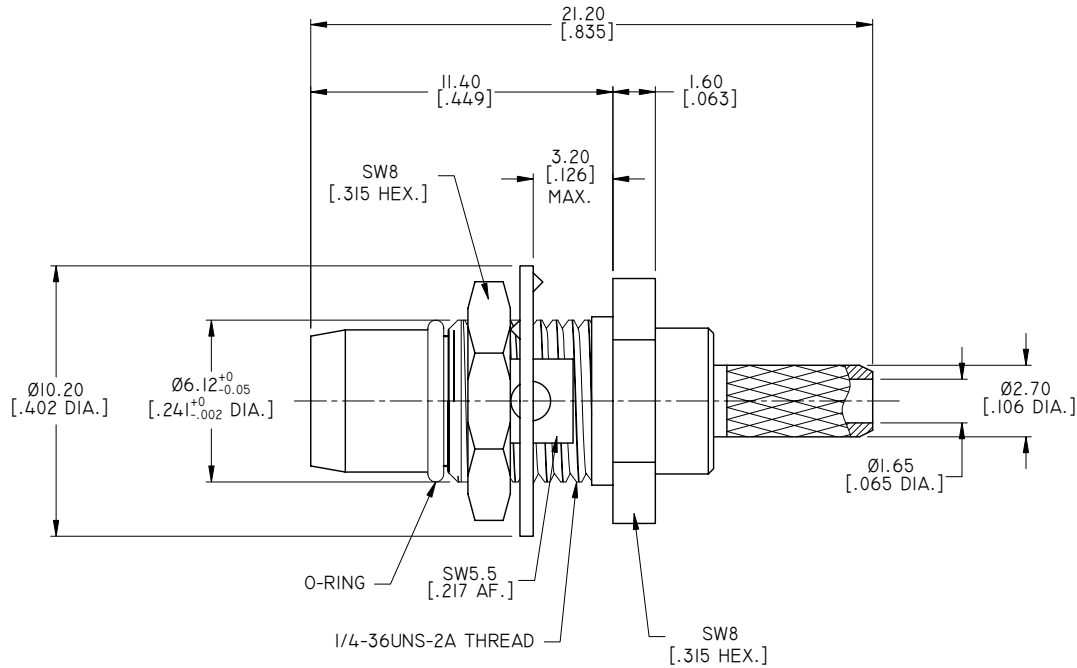

RECOMMENDED MOUNTING HOLE

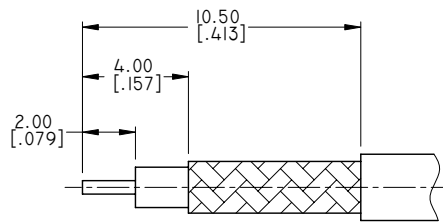

CABLE STRIPPING DIMENSIONS

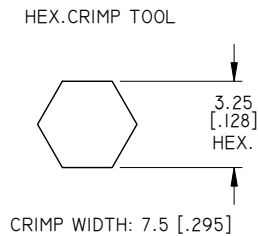

CRIMP WIDTH: 7.5 [.295]

DRAWN	X. B. YANG	DATE	09/21/18
CHECKED	W. YANG	DATE	09/21/18
APPROVED	J. QU	DATE	09/21/18
UNLESS OTHERWISE SPECIFIED DIMENSIONS ARE IN MILLIMETERS. DIMENSIONS IN [] ARE IN INCHES FOR CUSTOMER REFERENCE ONLY UNLESS OTHERWISE SPECIFIED TOLERANCE ARE:		THESE DRAWINGS AND SPECIFICATIONS ARE THE PROPERTY OF ANOISON ELECTRONICS LTD AND SHOULD NOT BE USED WITHOUT WRITTEN PERMISSION COPYRIGHT © 2018 ANOISON ELECTRONICS LTD	
.XX	±0.13 [.005"]		
.X	±0.20 [.008"]		
X	±0.50 [.019"]		
.X°	±1°		
X°	±2°		



TITLE BMA STRAIGHT PLUG CRIMP FOR LMR100/RG316/RG174 CABLE				
VIEW		PART NO. ANO I411-2007		
SIZE A3	SCALE 5:1	SHEET 1/1	REV. B	