

4

3

2

1

MATERIAL & FINISH:

- 1 BODY: BRASS, GOLD PLATED
- 2 CENTER CONTACT: BERYLLIUM COPPER ALLOY, GOLD PLATED
- 3 INSULATOR: PTFE
- 4 FASTENING NUT: BRASS, GOLD PLATED
- 5 LOCK WASHER: PHOSPHOR BRONZE, GOLD PLATED
- 6 O-RING: SILICONE RUBBER

ELECTRICAL DATA:

- 1 IMPEDANCE: 50 Ω
- 2 FREQUENCY RANGE: DC~6 GHz
- 3 VSWR: 1.25MAX.

ENVIRONMENTAL DATA:

- 1 TEMPERATURE RANGE: -55 °C~+165 °C
- 2 2011/65/EU (RoHS) AND 2015/863/(RoHS): COMPLIANT
- 3 1999/45/EC (REACH): COMPLIANT

REVISIONS			
REV.	DESCRIPTION	DATE	APPROVED
A	INITIAL RELEASE	12/22/23	J Q

D

D

C

C

B

B

A

A

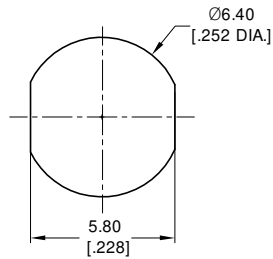

RECOMMENDED MOUNTING HOLE

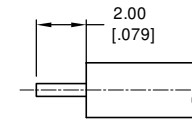
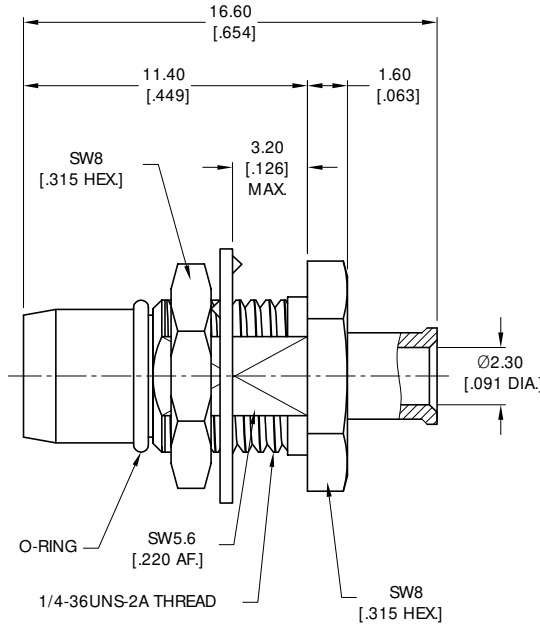

CABLE STRIPPING DIMENSIONS

DRAWN	P. C	DATE	12/22/23
CHECKED	X. Y	DATE	12/22/23
APPROVED	J Q	DATE	12/22/23
UNLESS OTHERWISE SPECIFIED DIMENSIONS ARE IN MILLIMETERS, DIMENSIONS IN [] ARE IN INCHES FOR CUSTOMER REFERENCE ONLY UNLESS OTHERWISE SPECIFIED TOLERANCE ARE:		THESE DRAWINGS AND SPECIFICATIONS ARE THE PROPERTY OF ANOISON ELECTRONICS LTD AND SHOULD NOT BE USED WITHOUT WRITTEN PERMISSION COPYRIGHT © 2023 ANOISON ELECTRONICS LTD	
.XX	±0.13 [0.005"]		
.X	±0.20 [0.008"]		
X	±0.50 [0.019"]		
.X°	±1°		
X°	±2°		



TITLE
BMA STRAIGHT PLUG BULKHEAD FRONT MOUNT SOLDER FOR .086 CABLE

VIEW	PART NO. ANO 1411-1032	SIZE A3	SCALE 5:1	SHEET 1/1	REV. A
------	---------------------------	------------	--------------	--------------	-----------

4

3

2

1