

MATERIAL & FINISH:

- 1 BODY: STAINLESS STEEL, GOLD PLATED
- 2 CENTER CONTACT: BERYLLIUM COPPER ALLOY, GOLD PLATED
- 3 INSULATOR: PTFE
- 4 FASTENING NUT: STAINLESS STEEL, PASSIVATED
- 5 LOCK WASHER: STAINLESS STEEL, PASSIVATED
- 6 O-RING: SILICONE RUBBER

ELECTRICAL DATA:

- 1 IMPEDANCE: 50 Ω
- 2 FREQUENCY RANGE: DC~18 GHz

ENVIRONMENTAL DATA:

- 1 TEMPERATURE RANGE: -55 °C~+165 °C
- 2 2011/65/EU (RoHS) AND 2015/863/(RoHS): COMPLIANT
- 3 1999/45/EC (REACH): COMPLIANT

REVISIONS			
REV.	DESCRIPTION	DATE	APPROVED
A	INITIAL RELEASE	12/21/23	J Q

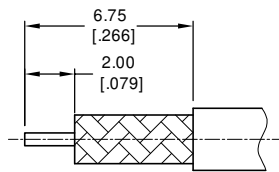
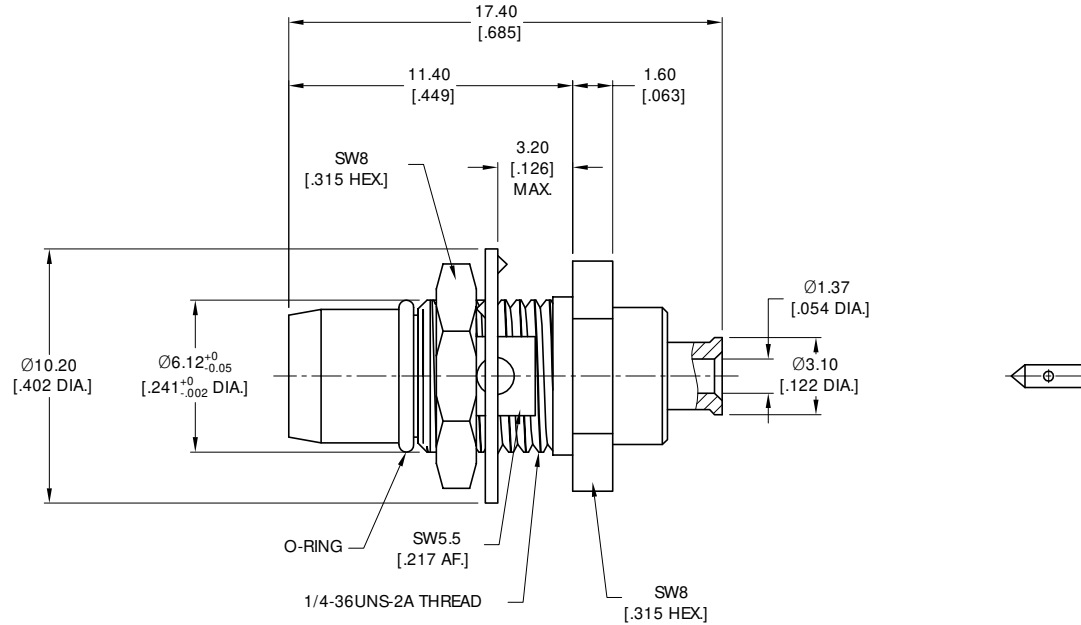

CABLE STRIPPING DIMENSIONS

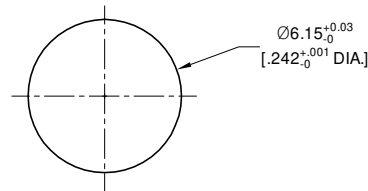

RECOMMENDED MOUNTING HOLE

DRAWN	P. C	DATE	12/21/23
CHECKED	X. Y	DATE	12/21/23
APPROVED	J Q	DATE	12/21/23
UNLESS OTHERWISE SPECIFIED DIMENSIONS ARE IN MILLIMETERS, DIMENSIONS IN [] ARE IN INCHES FOR CUSTOMER REFERENCE ONLY UNLESS OTHERWISE SPECIFIED TOLERANCE ARE:		THESE DRAWINGS AND SPECIFICATIONS ARE THE PROPERTY OF ANOISON ELECTRONICS LTD AND SHOULD NOT BE USED WITHOUT WRITTEN PERMISSION COPYRIGHT © 2023 ANOISON ELECTRONICS LTD	
XX	±0.13 [0.005"]		
X	±0.20 [0.008"]		
X	±0.50 [0.019"]		
X"	±1°		
X"	±2°		

TITLE BMA STRAIGHT PLUG BULKHEAD FRONT MOUNT SOLDE FOR .047 CABLE			
VIEW		PART NO. ANO 1411-1031	
		SIZE A3	SCALE 2.5:1
		SHEET 1/1	REV. A